



**AXELERA**  
ARTIFICIAL INTELLIGENCE

## Metis M.2 Max AI Accelerator Card Datasheet

---

2026-04-07  
AX-000920-DS-1  
Version: Issue 1

Copyright © | 2026 | Axelera AI BV | All rights reserved.

This documentation is protected by copyright and is intended solely for use as provided and in accordance with the applicable license agreement. Unauthorized use, reproduction, or distribution of this documentation, in whole or in part, is strictly prohibited.

## Document and proprietary information

### Document and information property

This document and the information contained herein are the property of Axelera AI. It must not be reproduced or otherwise disclosed without prior consent from Axelera AI.

### Trademarks

The Axelera "AX" logo is a trademark of Axelera AI BV, registered in the Netherlands and other countries. "AXELERA" and "METIS" are registered as word marks across a number of countries/regions.

All other product and company names and registered trademarks may be the property of their respective owners.

### Document revision history

Revision	Date	Description
1 - PRELIMINARY	2026-04-07	First issue.

## TABLE OF CONTENTS

DOCUMENT AND PROPRIETARY INFORMATION	2
1 INTRODUCTION	4
1.1 METIS M.2 MAX AI ACCELERATOR CARD OVERVIEW	4
1.2 KEY FEATURES	4
2 SPECIFICATIONS	5
2.1 BOARD AND PRODUCT CHARACTERISTICS	5
2.2 BOARD MECHANICAL DETAILS	6
2.3 CONNECTOR PINOUT	7
2.4 COOLING SOLUTION	9
2.5 SECURITY	10
3 SAFETY INFORMATION	11
4 INSTALLATION INSTRUCTIONS	12
5 TROUBLESHOOTING	12
6 SUPPORT	12
7 MODEL/PART NUMBERS	13
8 LEGAL NOTICE	14

# 1 Introduction

The Axelera AI Metis M.2 Max AI Accelerator Card is an advanced AI processing module that provides AI acceleration in edge systems with requirements for high performance and low power consumption.

This datasheet provides instructions and safety information to ensure the Metis M.2 Max AIPU AI Accelerator Card can be installed, operated, stored, maintained, repaired, and disposed of safely.

## 1.1 Metis M.2 Max AI Accelerator Card overview

The Metis M.2 Max AI Accelerator Card (referred to as the *Metis M.2 Max card*) has a single Axelera AI Metis AIPU (AI processing unit) chip that can deliver up to 214 TOPS. It is available in 2 GB, and 8 GB LPDDR4X memory configurations. The Metis M.2 Max design utilizes both DRAM interfaces of the Metis AIPU, doubling bandwidth compared to the original Metis M.2. It is designed to provide a significant boost for AI inference processing in any system that has an NGFF (Next Generation Form Factor) socket.



Figure 1: Axelera AI Metis M.2 Max card AI module fits to systems with an NGFF socket

## 1.2 Key features

- A high-performance M.2 card that features a Metis AIPU to enable state-of-the-art AI inference in small footprint devices.
- A single board can run inference on multiple cameras as well as support multiple independent parallel neural networks.
- A wide range of end-to-end AI pipelines and models are available out of the box.
- Hassle free evaluation and software integration thanks to [Voyager SDK](#).
- Uncompromised prediction accuracy thanks to advanced quantization tools.

## 2 Specifications

### 2.1 Board and product characteristics

The tables in this section list the board characteristics, including physical and software characteristics.

Table 1: Characteristics and of the Metis M.2 Max card

Specification	Description
Product name	Metis M.2 Max AI Accelerator Card
Main chip	Axelera AI Metis AIPU (AI Processing Unit)
Memory	2 GB or 8 GB LPDDR4X, utilizing both interfaces of the Metis AIPU.
Thermal solution	Active fan-cooled or no-cooling. For further details see section 2.4 <i>Cooling solution</i> .
Host interface	PCIe Gen. 3.0, 4-lanes Bandwidth: Up to 4 GB/s.
Certification	CE, FCC, UKCA, ROHS

Table 2: Physical characteristics

Specification	Description
Mechanical form factor	M.2 2280 M-key, requires H5.6 connector height. See 2.2 <i>Board mechanical details</i> .
Dimensions	22 mm x 80 mm. For full details see section 2.2 <i>Board mechanical details</i> .
Weight	100 grams for AXE-BME21M1####A04 (card with active cooling) 15 grams for AXE-BME21M1####B04 (card with no cooling)
Power Rating	The Metis M.2 Max card is compliant with PCI-SIG's M.2 Specification revision 4.0, which indicates the following power rating for M-key M.2 cards: <ul style="list-style-type: none"> <li>- Max. average power (over 1 s): 11.55 W (3500 mA at 3.3 V).</li> <li>- Peak power (over 100 <math>\mu</math>s): 23.1 W (7000 mA at 3.3 V).</li> </ul>
Thermal Design Power	11.0 W <sup>1</sup>

Table 3: Environmental characteristics

Specification	Description
Standard operating temperature (ambient)	-20~70°C
Storage temperature	-40~85°C
Storage Humidity	0%~85% RH, non-condensing

<sup>1</sup> 11 W is the default maximum power setting. The maximum power configuration can be lowered or raised via software commands.

## 2.2 Board mechanical details

This section provides the board package information of the Metis M.2 Max card.

- Figure 2 shows the board layout and dimensions.
- Table 4 describes the board and gives the package dimensions.

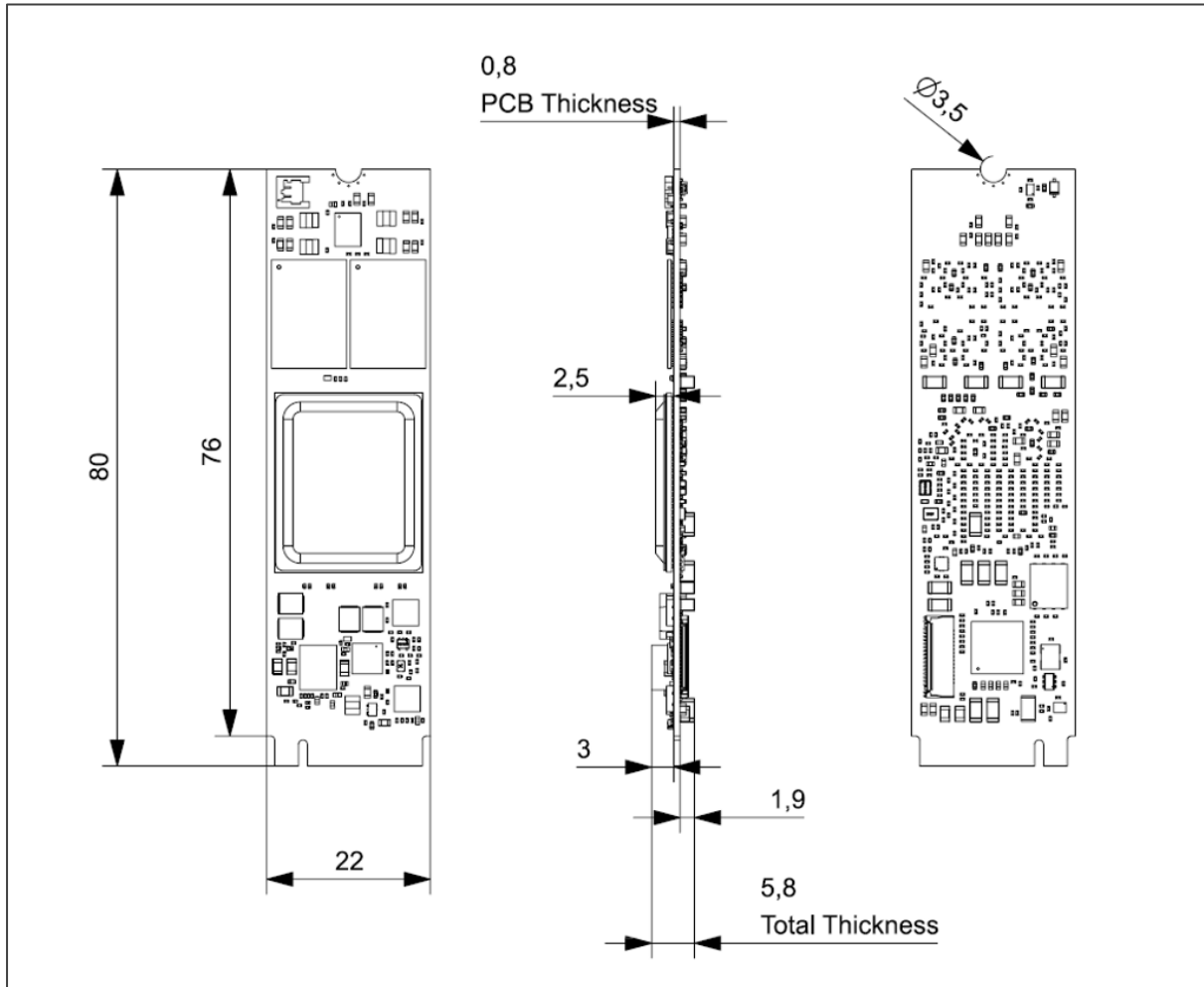

Figure 2: Board dimensions of the Metis M.2 Max card

Table 4: Metis M.2 Max card package dimensions

Item	Dimensions <sup>2</sup> (mm. tolerance $\pm 0.15$ mm)
<b>Top view</b>	
PCB board length	80.00
Board width	22.00
PCB mounting hole radius	3.50 $\pm 0.01$
Length of connector	4.00
<b>Edge dimensions</b>	
Max. height	5.8
Underside clearance	1.90
<b>Detail A</b>	
Board thickness	0.80 $\pm 0.08$
Edge chamfer length (to full thickness)	0.30 $\pm 0.25$
Edge chamfer angle	20.0° $\pm 5.^\circ$
<b>Underside view</b>	
M-key to PCB central line	6.125
PCB edge to PCB layer stack	1.00 $\pm 0.10$

## 2.3 Connector pinout

Table 5 shows the connector pinout for the Metis M.2 Max card alongside signals from the Metis AIPU chip.

Table 5: Metis M.2 Max card connector pinout and signals

Pin name	Pin reference	Signal name (other side)
+3.3V	2	3.3V Power
+3.3V	4	3.3V Power
+3.3V	12	3.3V Power
+3.3V	14	3.3V Power
+3.3V	16	3.3V Power
+3.3V	18	3.3V Power
GND	1	Ground
GND	3	Ground
GND	9	Ground
GND	15	Ground
GND	21	Ground

<sup>2</sup> Dimensions are nominal. Tolerance is  $\pm 0.15$  mm unless otherwise stated for individual items.

Pin name	Pin reference	Signal name (other side)
GND	27	Ground
GND	33	Ground
GND	39	Ground
GND	45	Ground
GND	51	Ground
GND	57	Ground
GND	71	Ground
GND	75	Ground
PETn0	41	PCIe TX Negative (Lane 0)
PETn1	29	PCIe TX Negative (Lane 1)
PETn2	17	PCIe TX Negative (Lane 2)
PETn3	5	PCIe TX Negative (Lane 3)
PETp0	43	PCIe TX Positive (Lane 0)
PETp1	31	PCIe TX Positive (Lane 1)
PETp2	19	PCIe TX Positive (Lane 2)
PETp3	7	PCIe TX Positive (Lane 3)
PERn0	47	PCIe RX Negative (Lane 0)
PERn1	35	PCIe RX Negative (Lane 1)
PERn2	23	PCIe RX Negative (Lane 2)
PERn3	11	PCIe RX Negative (Lane 3)
PERp0	49	PCIe RX Positive (Lane 0)
PERp1	37	PCIe RX Positive (Lane 1)
PERp2	25	PCIe RX Positive (Lane 2)
PERp3	13	PCIe RX Positive (Lane 3)
PCIE_REF_CLK_N	53	PCIe Reference Clock Negative
PCIE_REF_CLK_P	55	PCIe Reference Clock Positive
PERST#	50	PCIe Reset

## 2.4 Cooling solution

This section provides details of the fan-cooled heatsink used in the Metis M.2 Max card.

- Figure 3 shows the fan-cooled heatsink for the Metis M.2 Max card.
- Table 6 describes the package and gives the dimensions of the heatsink.

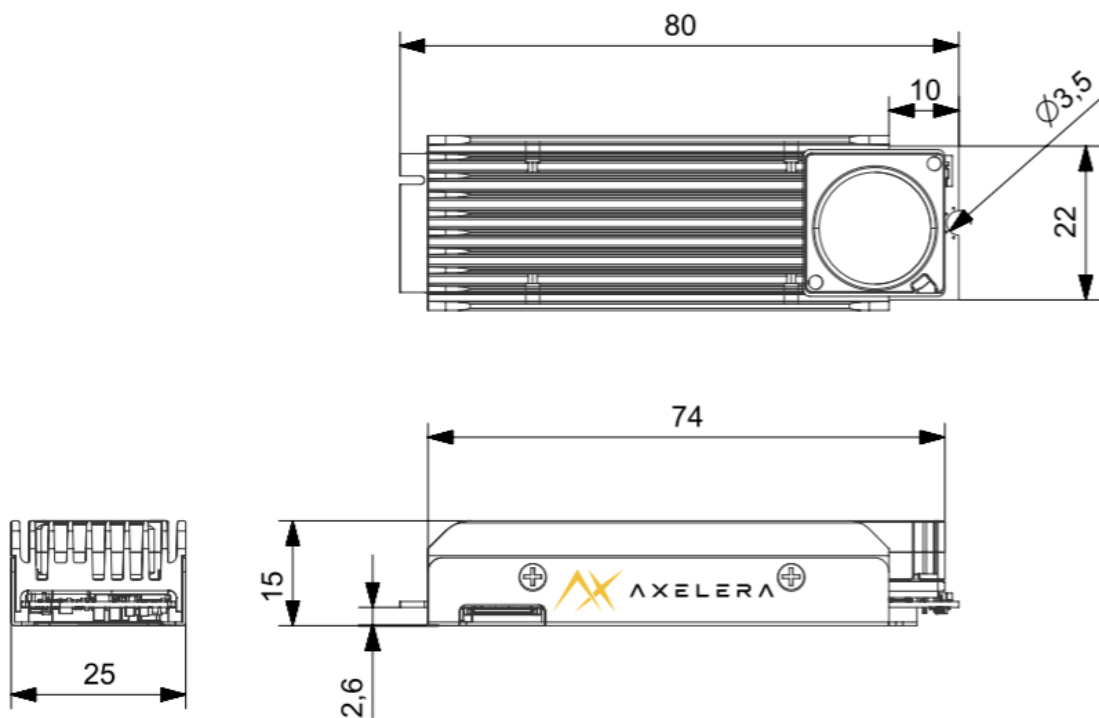

Figure 3: The fan-cooled heatsink for the Metis M.2 Max card

Table 6: Dimensions of the fan-cooled heatsink for the Metis M.2 Max card

Item	Dimensions (mm)
Total length	80.00
Length (heatsink only)	74.00
Height (to top of heatsink)	15.00
Width	25.00

The fan-cooled heatsink fan dissipates hot air on either side of the heatsink. Figure 4 shows the airflow directions: the blue arrow indicates cold air, the red indicates hot air.

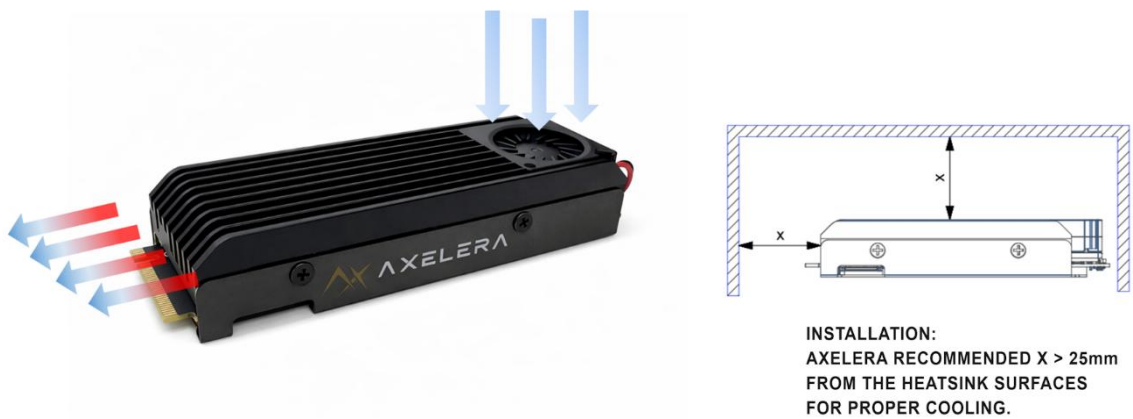

Figure 4: Air flow directions for the Metis M.2 Max card

## 2.5 Security

The Metis AIPU chip features a Root of Trust (RoT) that can be securely provisioned during chipset manufacturing. Firmware integrity protection is provided through secure boot and secure upgrade features built on this foundational RoT. For more information, please see Axelera contact details in section 6 *Support*.

### 3 Safety information

Before installing the Metis M.2 Max card and to ensure the safe use of the card, follow these guidelines:

- **General handling:**
  - Handle the card with care to avoid physical damage.
  - Wear an anti-static wrist strap during installation to prevent electrostatic discharge (ESD).
  - Disconnect the power source before handling, installing, or maintaining the product.
- **Installation:**
  - Ensure the card is installed in a M.2-compliant slot.
  - Verify that the power source complies with the product's power requirements.
- **Operation:**
  - Do not block the airflow to the fan or heatsink during operation.
  - Monitor system temperatures regularly to prevent overheating.
  - Operate within the specified ambient temperature range (-20°C to 70°C) as much as possible.
- **Storage:**
  - Store the product in a dry environment within -40°C to 85°C and 0%-85% relative humidity (non-condensing).
- **Maintenance:**
  - Regularly clean the fan and heatsink to prevent dust buildup.
  - Ensure software and firmware are updated to maintain performance and security.
  - Inspect the card and connectors periodically for signs of wear or damage.
- **Disposal:**
  - Dispose of the product in accordance with local electronic waste regulations.

**WARNING:** Improper handling, installation, or use may result in injury, equipment damage, or voiding of warranty.

## 4 Installation instructions

1. **Card installation:**
  - Align the card with the chosen M.2 slot in your system slot and gently insert it.
  - Secure the card using the bracket screws.
2. **Cooling verification:**
  - Ensure the fan is securely attached and unobstructed.
  - Verify airflow in the system chassis.
3. **Power connection:**
  - Confirm that your system provides sufficient power directly through the M.2 slot.
4. **Software Setup:**
  - Install the Voyager SDK for model configuration and optimization.

## 5 Troubleshooting

**Issue:** The system does not detect the card.

**Solution:**

1. Verify the card is properly seated in the M.2 slot.
2. Check the system's BIOS/UEFI to confirm M.2 lane availability.

**Issue:** Overheating during operation.

**Solution:**

1. Ensure adequate airflow within the chassis.
2. Clean the fan and verify its operation.

## 6 Support

For further information and support please visit:

- Axelera AI Community: <https://community.axelera.ai/>
- Axelera AI Customer Portal: <https://support.axelera.ai/>

## 7 Model/Part numbers

The Metis M.2 Max AI Accelerator Card is available in multiple configurations. Table 7 shows the part numbers for the available variants.

*Table 7: Metis M.2 Max AI Accelerator Card reference identification*

Part number	Description
AXE-BME21M1BN02A04	Metis M.2 Max AI Accelerator Card, 1-AIPU, 2 GB, active cooling, Rev 2.1
AXE-BME21M1BG02B04	Metis M.2 Max AI Accelerator Card, 1-AIPU, 2 GB, no cooling, Rev 2.1
AXE-BME21M1B008A04	Metis M.2 Max AI Accelerator Card, 1-AIPU, 8 GB, active cooling, Rev 2.1
AXE-BME21M1BC08B04	Metis M.2 Max AI Accelerator Card, 1-AIPU, 8 GB, no cooling, Rev 2.1

*Other memory variants and extended temperature support are available upon demand, subject to minimum order quantities.*

## 8 Legal notice

This document is provided for information purposes only and shall not be regarded as a warranty of a certain functionality, condition, or quality of a product. Axelera AI BV (“Axelera”) makes no representations or warranties, expressed or implied, as to the accuracy or completeness of the information contained in this document and assumes no responsibility for any errors contained herein. Axelera shall have no liability for the consequences or use of such information or for any infringement of patents or other rights of third parties that may result from its use. This document is not a commitment to develop, release, or deliver any Material (defined below), code, or functionality.

Axelera reserves the right to make corrections, modifications, enhancements, improvements, and any other changes to this document, at any time without notice.

Customers should obtain the latest relevant information before placing orders and should verify that such information is current and complete.

AXELERA products are sold subject to the Axelera standard terms and conditions of sale supplied at the time of order acknowledgement, unless otherwise agreed in an individual sales agreement signed by authorized representatives of Axelera and the Customer (“Terms of Sale”). Axelera hereby expressly objects to applying any customer general terms and conditions with regards to the purchase of the Axelera product referenced in this document. No contractual obligations are formed either directly or indirectly by this document.

Axelera products are not designed, authorized, or warranted to be suitable for use in medical, military, aircraft, space, or life support equipment, nor in applications where failure or malfunction of the Axelera product can reasonably be expected to result in personal injury, death, or property or environmental damage. Axelera accepts no liability for inclusion and/or use of Axelera products in such equipment or applications and therefore such inclusion and/or use is at customer’s own risk.

Axelera makes no representation or warranty that products based on this document will be suitable for any specified use. Testing of all parameters of each product is not necessarily performed by Axelera. It is customer’s sole responsibility to evaluate and determine the applicability of any information contained in this document, ensure the product is suitable and fit for the application planned by customer, and perform the necessary testing for the application in order to avoid a default of the application or the product. Weaknesses in customer’s product designs may affect the quality and reliability of the Axelera product and may result in additional or different conditions and/or requirements beyond those contained in this document. Axelera accepts no liability related to any default, damage, costs, or problem which may be based on or attributable to: (i) the use of the Axelera product in any manner that is contrary to this document or (ii) customer product designs.

No license, either expressed or implied, is granted under any Axelera patent right, copyright, or other Axelera intellectual property right under this document. Information published by Axelera regarding third-party products or services does not constitute a license from Axelera to use such products or services or a warranty or endorsement thereof. Use of such information may require a license from a third party under the patents or other intellectual property rights of the third party, or a license from Axelera under the patents or other intellectual property rights of Axelera.

Reproduction of information in this document is permissible only if approved in advance by Axelera in writing, reproduced without alteration and in full compliance with all applicable export laws and regulations, and accompanied by all associated conditions, limitations, and notices.

THIS DOCUMENT AND ALL AXELERA DESIGN SPECIFICATIONS, REFERENCE BOARDS, FILES, DRAWINGS, DIAGNOSTICS, LISTS, AND OTHER DOCUMENTS (TOGETHER AND SEPARATELY, "MATERIALS") ARE BEING PROVIDED "AS IS." AXELERA MAKES NO WARRANTIES, EXPRESSED, IMPLIED, STATUTORY, OR OTHERWISE WITH RESPECT TO THE MATERIALS, AND EXPRESSLY DISCLAIMS ALL IMPLIED WARRANTIES OF NONINFRINGEMENT, MERCHANTABILITY, AND FITNESS FOR A PARTICULAR PURPOSE. TO THE EXTENT NOT PROHIBITED BY LAW, IN NO EVENT WILL AXELERA BE LIABLE FOR ANY DAMAGES, INCLUDING WITHOUT LIMITATION ANY DIRECT, INDIRECT, SPECIAL, INCIDENTAL, PUNITIVE, OR CONSEQUENTIAL DAMAGES, HOWEVER CAUSED AND REGARDLESS OF THE THEORY OF LIABILITY, ARISING OUT OF ANY USE OF THIS DOCUMENT, EVEN IF Axelera HAS BEEN ADVISED OF THE POSSIBILITY OF SUCH DAMAGES. Notwithstanding any damages that customer might incur for any reason whatsoever, Axelera's aggregate and cumulative liability towards customer for the products described herein shall be limited in accordance with the Terms of Sale for the product.

### **Trademarks**

The Axelera "AX" logo is a trademark of Axelera AI BV, registered in the Netherlands and other countries. "AXELERA" and "METIS" are registered as word marks across a number of countries/regions. Other company and product names may be trademarks of the respective companies with which they are associated.